

DATASHEET  
for  
**Universal Navigation Light**  
Product UNL L30001-00-023 / Yacht Applications



Optonaval Universal Navigation Light (UNL) Double Stern Light & Suez Stop Light is a member of the Optonaval Navigation Light family, a modular platform, based on a universal housing design. The rigid design of the massive seawater resistant aluminum body is optimized for performance in extreme marine environments.

## PRODUCT SPECIFICATION

ELECTRICAL SPECIFICATIONS	
Supply voltage	24 V DC
Power	9 W rated / 16 W max.
OPERATING CONDITIONS	
Ambient temperature	-20°C to 50°C
Ingress protection level	IP66/67
Shock	acc. to EN 14744
Vibration	acc. to EN 60945
EMC	acc. to EN 60945
Night Vision	compatible
MECHANICAL SPECIFICATIONS	
Dimensions	Ø100x181 mm
Weight	approx. 1,8 kg
Housing color	RAL Classic
Housing material	sea water resistant aluminum alloy
Surface coating	anodized or powder coated (preanodized)
Tube material	PMMA
AFT cable gland variant	L30001-00-024
OPTICAL/LIGHT SPECIFICATIONS	
Light source	LED
Light colors	1x RD, 2x WH
Beam angle	135° horizontal
Beam angle vertical	±7,5°
Light Range	3 NM
ADDITIONAL DOCUMENTS	
Installation Drawing	L30001-50-001_InstallationDrawing
Installation Manual	L30001-51-001_InstallationManual
Operating Manual	L30001-81-001_OperatingManual
Maintenance Manual	L30001-82-001_MaintenanceManual

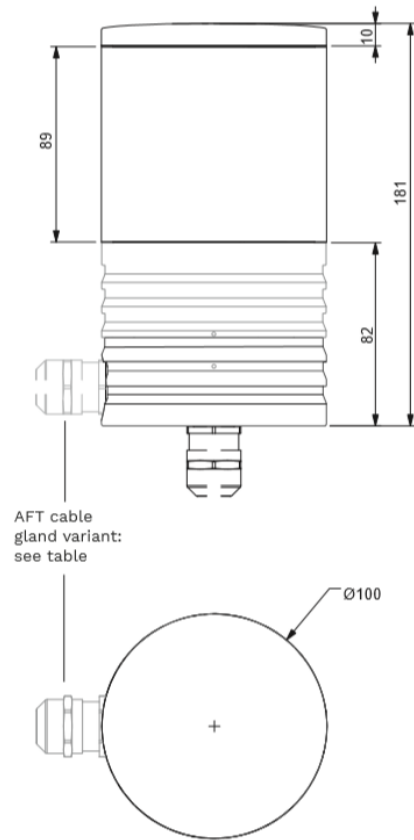

## APPLICATIONS

ON-Part No.	Product type
L30001-00-023	UNL - DOUBLE STERN LIGHT & SUEZ STOP LIGHT - 135° - 3NM - WH&RD - CBL BTM

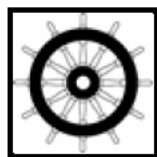

Notified Body  
No.: **0098**